

2. Alignment and Adjustments

2-1 When entering the service mode:

1. Turn on the TV, and then select "STANDARD" on the picture adjustment mode.
2. Turn off the TV (STAND-BY).
3. Enter the service mode by pressing the remote control keys in the following sequence :

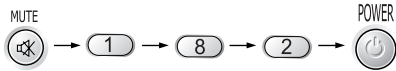

Note : If necessary, re-do steps 1~3.

Initial display when the service mode is switched.

DEFLECTION
 VIDEO ADJUST 1
 VIDEO ADJUST 2
 VIDEO ADJUST 3
 VIDEO ADJUST 4
 VIDEO ADJUST 5
 VIDEO ADJUST 6
 VERSION INFORMATION
 RESET

4. Service Mode Control Keys

MAIN MENU	MENU DISPLAY
▲ / ▼	Select item by moving cursor
◀ / ▶	Decrease or increase the adjustment values

2-2 Factory Data

 **DVI connection item is corresponded to DVI application model.
(HCN559W/HCN5529W)**

2-2-1 Defection

ITEM	EXPLANATION	Register Name & Control Format	SPEC R.	OSD R.	DEFAULT (DTV/ NT)
V Amp	Gain Adjustment for V_DRV Signal	V_SIZE	0 ~ 63	0 ~ 63	31
V Shift	Vertical Picture Scroll Control	V_SCROLL	0 ~ 63	0 ~ 63	31(Fix)
H EW	DC Bias Adjustment for EW_DRV Signal	H_SIZE	0 ~ 63	0 ~ 63	31
H Shift	AFC Phase Control	H_POSITION	0 ~ 63	0 ~ 63	42(Fix)
V Linearity	Gain adjustment for V_DRV signal's 2'(feet) component	V_LIN	0 ~ 15	0 ~ 15	7
Upper Linearity	Top vertical linearity adjustment for picture	UP_VLIN	0 ~ 15	0 ~ 15	0
Lower Linearity	Bottom vertical linearity adjustment for picture	LO_VLIN	0 ~ 15	0 ~ 15	0
V SC	Gain adjustment for vertical S component	S_CORRECTION	0 ~ 15	0 ~ 15	7
H Parabolra	Compensation value adjustment for horizontal pin bias	PIN_AMP	0 ~ 63	0 ~ 63	31
Upper Corner	Gain adjustment for top edge EW_DRV signal	UP_CPIN	0 ~ 63	0 ~ 63	31
Lower Corner	Gain adjustment for bottom edge EW_DRV signal	LO_CPIN	0 ~ 63	0 ~ 63	31
H Trapezium	Center timing adjustment for EW_DRV signal	PIN_PHASE	0 ~ 63	0 ~ 63	31
Bow	HAFC phase adjustment by Parabola wave	AFC_BOW	0 ~ 63	0 ~ 63	31
Angle	HAFC phase adjustment by Sawtooth wave	AFC_ALGLE	0 ~ 63	0 ~ 63	31
V Position	DC bias adjustment for V_DRV signal	V_POSITION	0 ~ 63	0 ~ 63	31
Up UCG	Gain adjustment for extreme top edge EW_DRV signal	UP_UCG	0 ~ 3	0 ~ 3	0
Lo UCG	Gain adjustment for extreme bottom edge EW_DRV signal	LO_UCG	0 ~ 3	0 ~ 3	0
CXALeft Blk	HBLK width adjustment for the left side of picture	LEFT_BLK	0 ~ 63	0 ~ 63	55
CXARight Blk	HBLK width adjustment for the right side of picture	RIGHT_BLK	0 ~ 63	0 ~ 63	15
DVI HS 1080i	DVI horizontal shift 1080i		0 ~ 63	0 ~ 63	30
DVI HS 720p	DVI horizontal shift 720P		0 ~ 63	0 ~ 63	30
DVI HS 480p	DVI horizontal shift 480P		0 ~ 63	0 ~ 63	30

2-2-2 Video Adjust 1

ITEM	EXPLANATION	Register Name & Control Format	SPEC Range	OSD Range	DEFAULT (DTV/ NT)	
R Cutoff	Rch reference level adjustment for IK_IN 00: -10dB / 1F: 0dB / 3F: +6dB	R_CUTOFF	0 ~ 63	0 ~ 63	25	
G Cutoff	Gch reference level adjustment for IK_IN	G_CUTOFF	0 ~ 63	0 ~ 63	25	
B Cutoff	Bch reference level adjustment for IK_IN	B_CUTOFF	0 ~ 63	0 ~ 63	25	
Color On/Off	On: Writes 00h as color gain		0 ~ 63	0/1	1	
CB Offset	Canceling DC_OFFSET for Cb signal	CB_OFFSET	0 ~ 63	0 ~ 63	32	
CR Offset	Canceling DC_OFFSET for Cr signal	CR_OFFSET	0 ~ 63	0 ~ 63	32	
R Drive	Rch drive gain adjustment 00: -4.67dB / 29: 0dB(2.56Vpp) / 3F: +1.33dB	R_DRIVE	0 ~ 63	0 ~ 63	35	
G Drive	Rch drive gain adjustment	G_DRIVE	0 ~ 63	0 ~ 63	35	
B Drive	Rch drive gain adjustment	B_DRIVE	0 ~ 63	0 ~ 63	35	
Sub Bright	SUB_BRIGHT adjustment 00: -14 IRE / 1F: 0 IRE / 3F: +14 IRE	SUB_BRIGHT	0 ~ 63	0 ~ 63	20	
Sub Contrast	Sub Picture control	SUB_CONT	0 ~ 15	0 ~ 15	8	
Sub Color	User Menu Color(0~40) + Sub Color(0~23)		0 ~ 63	0 ~ 23	15	
Sub Tint	Hue control	HUE	0 ~ 63	0 ~ 63	11	
CTI Level	CTI gain setting	CTI_LEV	0 ~ 3	0 ~ 3	0	1
COL Axis	Color detection axis setting: 2=mode for NTSC US	COL_AXIS	0 ~ 3	0 ~ 3	2	
LTI Level	LTI gain setting: 0 (off),3 (strong)	LTI_LEV	0 ~ 3	0 ~ 3	1	1
Melody Volume	Beeper volume setting (Base frequency: 1 KHz)		0 ~ 255	0 ~ 20	4	
LTI Mode	LTI mode setting (See Attachment 3.)	LTI_MODE	0 ~ 3	0 ~ 3	2	2
System	Signal band select : 0(Normal),1(FF),2(HD),3(DTV)	SYSTEM	0 ~ 3	0 ~ 3	2	2

2-2-3 Video Adjust 2

ITEM	EXPLANATION	Register Name & Control Format	SPEC R.	OSD R.	DEFAULT (DTV/NT)	
ABL Level	ABL Mode Setting : 3=Strong	ABL_MODE	0 ~ 3	0 ~ 3	3	
Gamma	RGB output gamma compensation	GAMMA	0 ~ 3	0 ~ 3	1	
DPIC Level	Black expansion adjustment 0: off / 1: 25IRE / 2: 30IRE / 3: 35IRE	DPIC_LEV	0 ~ 3	0 ~ 3	3	
DC Trans	DC transmission ratio setting for Luma signal	DC_TRAN	0 ~ 3	0 ~ 3	3	
ABL TH	Threshold voltage adjustment for ABL_IN input 0: Vth 0.8V / 3: Vth 1.9V	ABL_TH	0 ~ 15	0 ~ 15	15	
VM Level	VM_OUT level adjustment	VM_LEV	0 ~ 3	0 ~ 3	2	2
VM Coring	VM_OUT coring level setting	VM_COR	0 ~ 3	0 ~ 3	0	0
VM f0	VM_OUT f0 setting : 0(low),1(medium),2(high)	VM_F0	0 ~ 3	0 ~ 3	2	2
VM Limit	VM_OUT limited level setting	VM_LMT	0 ~ 3	0 ~ 3	3	3
VM Delay	VM_OUT phase adjustment (based on R-OUT)	VM_DLY	0 ~ 3	0 ~ 3	0	0
SHP CD Gain	Setting sharpness gain for high color saturation in case that input Cr signal is 100% saturated with color : 0 = 0 dB / 3 = + 6 dB	SHP_CD	0 ~ 3	0 ~ 3	1	1
SHP f0	Sharpness f0 setting (See Attachment 1.)	SHP_F0	0/1	0/1	0	0
SHP f1 Gain	High f0 \Rightarrow Sharpness gain control: 0~3dB	SHP_F1	0 ~ 3	0 ~ 3	3	3
Pre/Over	Sharpness f0 setting (See Attachment 2.)	PRE/OVER	0 ~ 3	0 ~ 3	1	1
AKB Time	AKB Bch reference pulse timing setting	AKBTIM	0 ~ 32	0 ~ 32	11	
S ABL	S_ABL Gain Setting	S_ABL	0 ~ 3	0 ~ 3	3	
P ABL	RGB output DC level setting for peak ABL	P_ABL	0 ~ 15	0 ~ 15	10	
Picture Limit	RGB signal size limit setting 0 : 115 IRE / 1 : 123 IRE 2 : 130 IRE / 3 : 136 IRE	PLIMIT_LEV	0 ~ 3	0 ~ 3	3	

2-2-4 Video Adjust 3

ITEM	EXPLANATION	Register Name & Control Format	SPEC R.	OSD R.	DEFAULT (DTV/ NT)
H Comp	High voltage fluctuation compensation setting 0 : 0 V / F : -0.3 V	H_COMP	0 ~ 15	0 ~ 15	0
V Comp	High voltage fluctuation compensation setting 0 : 0 % / F : - 12 %	V_COMP	0 ~ 15	0 ~ 15	0
Pin Comp	High voltage fluctuation compensation setting 0 : off / 7 : -10 %		0 ~ 7	0 ~ 7	0
AFC Comp	High voltage fluctuation compensation setting 0 : 0 % / 7 : +0.75 % (to left)	AFC_COMP	0 ~ 7	0 ~ 7	0
CG HAO	 Operates when the cursor accurately locates. Writes the original value when the cursor leaves.	H EW + DEFAULT	0 ~ 63	0 ~ 20	15
CG VAO		V Amp + DEFAULT	0 ~ 63	0 ~ 20	15
BKG Level	Screen background brightness setting in case of no signal	OSG Control Reg.	0 ~ 63	0 ~ 63	25
Noise High Ref	Reference value for input noise high level	NOISEMEM	0 ~ 254	0 ~ 100	40
Noise Low Ref	Reference value for input noise low level	NOISEMEM	0 ~ 254	0 ~ 100	2
Noise High Value	High value for strong noise reduction	TNRCLYM+TNRCLCM	0 ~ 255	0 ~ 15	1
Noise Low Value	Low value for slight noise reduction	TNRCLYM+TNRCLCM	0 ~ 255		3
APK BP	Peaking amount of Bandpass filter		0 ~ 31	9 ~ 15	9
ATH BP	Second region of Bandpass filter		0 ~ 15	8 ~ 11	8
APK HP	Peaking amount of Highpass filter		0 ~ 31	9 ~ 15	9
ATH HP	Second region of Highpass filter		0 ~ 15	4 ~ 7	5
CM THRESHOLD	Threshold setting for carrier mute	CM_THRESH	0 ~ 2047	20 ~ 80	42
CM Det Time	Chatter time setting for SAP detection		0 ~ 2 0	0.5sec/1step	0

2-2-5 Video Adjust 4

ITEM	EXPLANATON	Register Name & Control Format	SPEC R.	OSD R.	DEFAULT (DTV/ NT)
YC RF Delay	Luma Delay Adjust 10000 : 800 ns 00000 : no delay 01111 : -700 ns	YCDELM	-16 ~ 15	0 ~ 31	9
YC AV Delay			-16 ~ 15	0 ~ 31	9
PIP YC RF Delay	Luma/Chroma Delay Adjust (Slave Address: 88h)	LDLY	+1 ~ -7	0 ~ 8	4
PIP YC AV Delay					4
Chroma Bandwidth RF	Chroma Bandwidth Selector	CHRFM	0 ~ 63	0 ~ 63	28
Chroma Bandwidth Video					28
Chroma Bandwidth SVideo					30
IF Compensation RF	IF Compensation Set 000 : pal prefiltering 001 : pal prefiltering + I F 010 : prefiltering 011 : IF 6dB 100 : flat	IFCOMPM	0 ~ 4	0 ~ 4	2
IF Compensation Video					4
IF Compensation SVideo					4
AD9888 R Gain	Input brightness control for each channel Contrast/Brightness Control ☞ The default, "100", is based on the Initial_Write value of AD9888 (The average of AD9888 distributions is used as reference value.) ☞ See Attachment 5. (Page 11)	Red Gain	0 ~ 255	0 ~ 200	100
AD9888 G Gain		Green Gain			100
AD9888 B Gain		Blue Gain			100
AD9888 R Offset		Red Offset	0 ~ 254	0 ~ 200	100
AD9888 G Offset		Green Offset			100
AD9888 B Offset		Blue Offset			100
AD9888 Phase	Phase adjust		0 ~ 255	0 ~ 255	122
AD9888 Sync LV	Sync separator threshold		0 ~ 255	0 ~ 255	24

2-2-6 Video Adjust 5

ITEM	EXPLANATION	ITEM 1	SPEC R.	OSD R.	DEFAULT (DTV/NT)	
Reset P.Mode	Factory Reset P.Mode setting				Dynamic	
Dynamic	Changing initial condition for each P.Mode ☞ Make sure to write P.Mode value that was set in Reset P.Mode both before and after entering the Adjustment menu. (However, write the adjustment value when you are in the menu.) ☞ Adjust the color tone settings (given below) also.	Contrast Brightness Sharpness Color Tint		0 ~ 100	100 45 60 50 50	
Standard		Contrast Brightness Sharpness Color Tint		0 ~ 100	80 50 50 45 50	
Movie		Contrast Brightness Sharpness Color Tint		0 ~ 100	35 75 25 57 44	
Custom		Contrast Brightness Sharpness Color Tint		0 ~ 100	80 50 50 45 50	
Initial Color Tone	Initial color tone value setting				Cool 1	
Cool 2	Offset setting for each color tone ☞ Add the offset to R/B drive and subtract the offset from R/B cutoff. Then, write and display the results.	RC Offset BC Offset RD Offset BD Offset		0 ~ 63	21 32 27 34	29 32 32 32
Cool 1		RC Offset BC Offset RD Offset BD Offset		0 ~ 63	32 32 32 32	32 32 32 32
Normal	Offset setting for each color tone	RC Offset BC Offset RD Offset BD Offset		0 ~ 63	37 23 33 29	34 28 36 29
Warm1		RC Offset BC Offset RD Offset BD Offset		0 ~ 63	39 19 41 17	36 21 39 21
Warm2		RC Offset BC Offset RD Offset BD Offset		0 ~ 63	40 14 41 9	35 17 43 16

2-2-7 Video Adjust 6

ITEM	EXPLANATION	ITEM 1	CONTROL REG.	SPEC R.	OSD R.	DEFAULT (DTV/ NT)	
NR SCALEMAX Y	Temporal NR Gain		0x293[15:8]	0 ~ 255	0 ~ 255	48	32
NR SCALEMAX C			0x293[7:0]	0 ~ 255	0 ~ 255	48	32
NR SCALEMIN Y			0x294[15:8]	0 ~ 255	0 ~ 255	16	16
NR SCALEMIN C			0x294[7:0]	0 ~ 255	0 ~ 255	16	16
NR HPF TH	Spatial NR Gain		0x298[6:4]	0 ~ 7	0 ~ 7	0	0
NR EDGE TH			0x298[2:0]	0 ~ 7	0 ~ 7	5	4
NR SEL	NR Mode Select		0x29F[13:12]	0 ~ 3	0 ~ 3	2	3
CE UPPER	CE Upper Boundary		0x2B0[7:0]	0 ~ 255	0 ~ 255	240	220
CE CUTOFF	CE Lower Boundary		0x2B0[15:8]	0 ~ 255	0 ~ 255	32	32
CE GAIN L	CE Gain		0x2B3[15:8]	0 ~ 255	0 ~ 255	75	64
CE GAIN U			0x2B3[7:0]	0 ~ 255	0 ~ 255	75	64
DEC_GAIN L	DEC Gain		0x2D5[15:8]	0 ~ 255	0 ~ 255	96	75
DEC_GAIN U			0x2D5[7:0]	0 ~ 255	0 ~ 255	96	75
DE GAIN	DE Gain		0x317[6:0]	0 ~ 127	0 ~ 127	80	64
DE NOISEDET GAIN			0x316[3:0]	0 ~ 15	0 ~ 15	10	8
DE CORING	DE Coring Value		0x311[5:0]	0 ~ 63	0 ~ 63	0	0
DE H CONT	DE Horizontal Shoot Reduce		0x31C[9:0]	0 ~ 1023	0 ~ 255	128	8
DE V CONT	DE Vertical Shoot Reduce		0x31D[9:0]	0 ~ 1023	0 ~ 255	128	32
BS GAIN	Black Stretch Gain		0x331[15:5]	0 ~ 2047	367 ~ 397	375	375
WS GAIN	White Stretch Gain		0x332[15:5]	0 ~ 2047	367 ~ 397	375	375
CTE GAIN	CTE Gain		0x352[8:0]	0 ~ 511	0 ~ 255	176	176
WTE GAIN	WTE Gain		0x345[9:0]	0 ~ 1023	250 ~ 350	300	300
SUB_BRIGHT TR	Bright Control		0x364[7:0]	-128 ~ 127	0 ~ 255	128	128
SUB_BRIGHT G			0x365[7:0]	-128 ~ 127	0 ~ 255	128	128
SUB_BRIGHT B			0x366[7:0]	-128 ~ 127	0 ~ 255	128	128
SUB_CONTRAST R	Contrast Control		0x361[7:0]	0 ~ 255	0 ~ 255	128	128
SUB_CONTRAST G			0x362[7:0]	0 ~ 255	0 ~ 255	128	128
SUB_CONTRAST B			0x363[7:0]	0 ~ 255	0 ~ 255	128	128

2-3 Screen Change (When adjusting I²C Bus Geometric items)

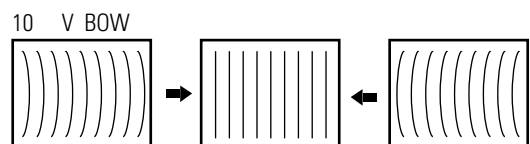
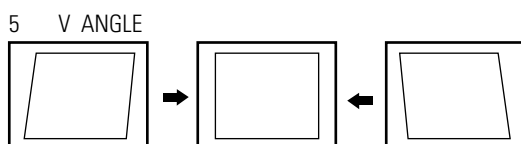
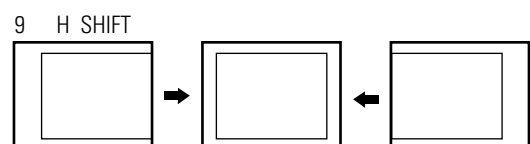
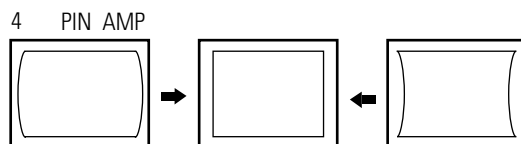
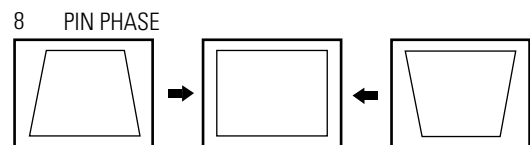
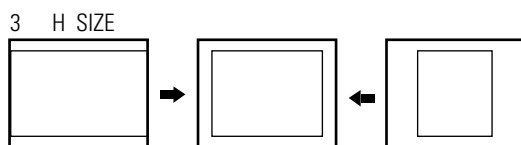
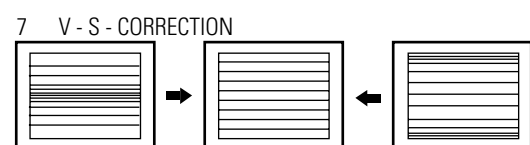
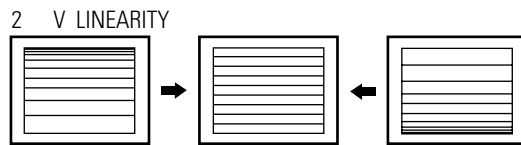
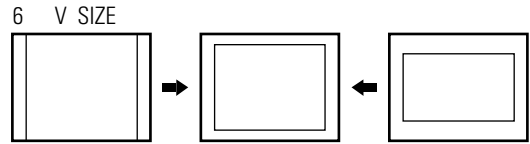
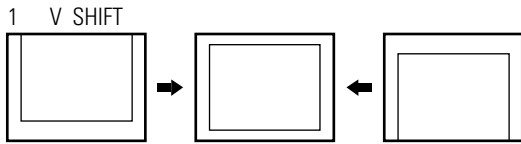

2-4 Other Adjustments

2-4-1 Screen Adjustment

1. Warm up the TV for at least 30 minutes.
2. Select the "STANDARD" video mode.
3. Turn to the Video Mode (No Signal) using a remote-control.
4. Connect an oscilloscope to RK,GK,BK.
5. Adjust the VR (VR501, VR531, VR561) screen so that RK, GK, BK pulse is 20Vp-p each. (Turn the R,G,B VR screen fully counterclockwise in the area of each flyback line.)

2-4-2 White Balance Adjustment

1. Select the "STANDARD" video mode.
2. Input 100% white pattern.
3. In the stand-by mode, press the remote-control keys in the following sequence:
4. Warm up the TV for at least 30 minutes.

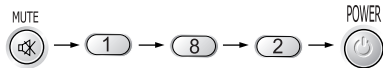

5. W/B Adjustment Instruction
 - ① RF-NT ; Set to 'Color-off'. Then read the coordinates. (Target-A)
 - ② RF-NT ; Adjust high light brightness and low light white balance for AD9888. Set to 'color-on'. (Target-A) → CH1
 - ③ RF-NT ; Set to 'color-off'. Then adjust CXA2165. (Adjustment coordinates : specified spec) → CH2
 - ④ DVI(DTV)-Mode conversion ; Set to 'color-off'. Then adjust CXA2165. (Adjustment coordinates ; specified spec) → CH3
 - ⑤ DVI(DTV)-Mode conversion ; Set to 'Color-on'. Then adjust CR/CB for CXA2165. (Adjustment coordinates : low light coordinate spec) → CH4
6. Adjustment Sequence



CH-1 ; RF		CH-2 ; RF		CH-3 ; DVI(DTV)		CH-4 ; DVI(DTV)	
Color	On	Color	Off	Color	Off	Color	On
R-offs	0	R-C	0	R-C	0	CR	0
G-offs	0 L/L(Y)	G-C	Fix	G-C	Fix		
B-offs	0	B-C	0	B-C	0	CB	0
R-Gain	255(Fix)	R-D	0	R-D	0		
G-Gain	0 H/L(Y)	G-D	Fix	G-D	Fix		
B-Gain	255(Fix)	B-D	0	B-D	0		
		SCT	0	SCT	0		
		SBT	0	SBT	0		
AD9888 Offset adjustment		CXA2165 adjustment		CXA2165 adjustment		CXA2165 CR,CB adjustment	
Target ; initial value		Target ; selected spec		Target ; selected spec		Target ; selected spec (L/L)	

7. Press the Menu key to exit.

2-4-3 Sub-Brightness Adjustment

1. Input a sub-brightness adjustment signal. (TOSHIBA PATTERN)
2. In the stand-by mode, press the remote-control keys in the following sequence :



3. Select SBT by pressing the  keys.
4. Adjust so that the 63 step on the right side of the screen is not seen (Use the  keys).
5. Press the Menu key to exit.

2-4-4 High Voltage (29KV) Check

PRECAUTION

1. Input a lion head pattern.
2. Select "STANDARD" video mode.
3. Warm up the TV for at least 10 minutes.
4. Use a 1000:1 probe.

ADJUSTMENT

1. Connect the (+) terminal of the 1000:1 probe to the high voltage distributor and the (-) terminal to GND (located on the deflection board).
2. Adjust RR471S (located on the deflection board) so that the digital meter indicates DC 29V ± 0.1V.

2-4-5 F.S. (Fail Safe) Adjustment

Note : The finished product has VR (RR402S) adjusted and glued at the factory. If necessary, do the F.S. adjustments in the following sequence.

1. Use a digital multimeter.
2. Connect the digital multimeter to the JIG pin (DZ482S) terminals
3. Adjust VR (RR402S) so that the voltage becomes 2.25V.

4. After the adjustments are complete, be sure to glue VR (RR402S) correctly.

2-4-6 F.S. (Fail Safe) Circuit Check

Note : The F.S. Circuit check must be performed after servicing.

1. Turn on the TV.
2. Select the "STANDARD" video mode.
3. Short F/S Test point (located on the SUB PCB). Then, both sound and picture disappear. (Note: Even if the shorted terminals are removed, both sound and picture do not appear. This proves the F.S. circuit is working.)
4. To restore both sound and picture, turn off the TV and reset it after about 30 seconds.

2-4-7 Static Focus Adjustment

PRECAUTION

1. Select the "STANDARD" video mode.
2. Input a crosshatch pattern.
3. Cover the lenses that are not being adjusted.
4. Connect a convergence jig and read data.
5. Adjust the lens for best focus. (See Fig. 2-1)

STATIC FOCUS (CONTINUED)

Vary the focus pack VR (Red, Blue) on the front cabinet. Adjust the TV for best possible focus around the center of the crosshatch pattern, without losing overall screen balance. Figure Crosshatch Pattern Examine these points together.

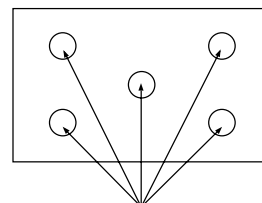

Examine these points together

Fig. 2-1 Crosshatch Pattern.

2-4-8 Lens Focus Adjustment

PRECAUTIONS

1. Do this adjustment after the static focus adjustment and the tilt adjustment.
2. Select the "STANDARD" video mode.
(Contrast:100, Brightness:50)
3. Input a crosshatch pattern.
6. Red lens adjustment
Set the Red lens at the point where Orange becomes Crimson.
7. Blue lens adjustment
Set the Blue lens at the point where Purple becomes Green.

ADJUSTMENT

1. Loosen the lens screws.
2. Cover the two lenses that are not being adjusted.
3. Adjust the lens, observing the color aberration vertically and horizontally within 3 blocks of the center of the crosshatch pattern.
4. When the lens is turned clockwise, the color aberration will change as follows:

<u>Lens</u>	<u>Color Aberration Change</u>
R	Orange - Crimson
G	Blue - Red
B	Purple - Green

5. Green lens adjustment:
Set the lens at the point where Blue just changes to Red. If the color aberration is irregular throughout the picture screen, adjust the lens to show Red color aberration (approximately 1~3 mm area) within a 3-block grid around the horizontal center-line. If the color aberration is irregular, adjust the lens as shown in the diagram below. (Accurate alignment of Green is important for overall color quality.)

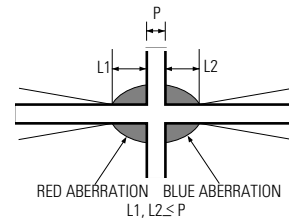





Fig. 2-2 Color Aberration

2-5 Beam alignment Adjustments

1. Select the "STANDARD" video mode.
2. Warm up the set at least for 10 minutes.
3. Enter the Convergence mode by pressing the remote control buttons in the following sequence

:  →  →  → 

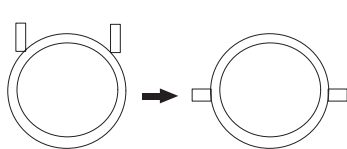

4. Set the Beam Alignment Adjustment CY to Zero magnetic field area.



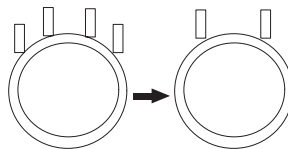

(Creation of CPM Zero Magnet)

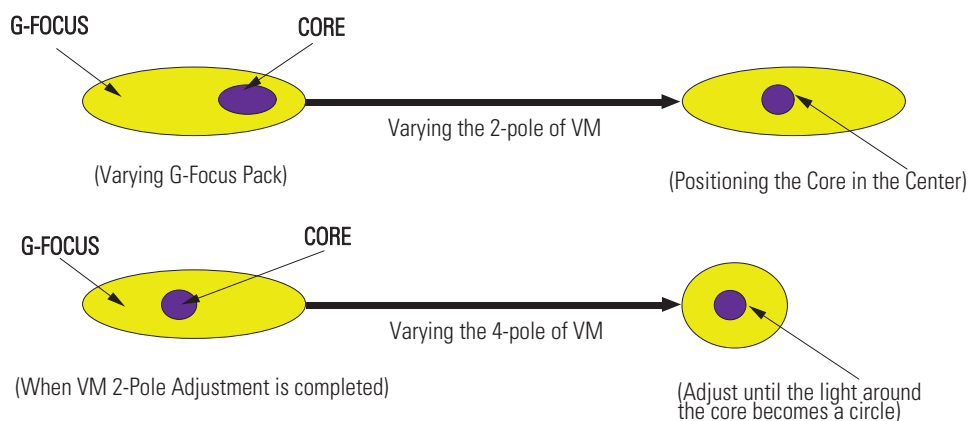

(Creation of the 2-pole/4-pole zero magnets)

5. Press the  button on the remote control, and a vibrating dot-pattern appears.
6. Adjust the Focus-pack VR for defocusing.
7. Mute the other patterns (R/B) other than G-PATTERN.
(Use  /  buttons on the remote control.)
8. Adjust the 2, 4 polarities of VM-COIL as shown in figure below.
9. Adjust the G-Focus until any light around the core disappears.



10. Adjust G-Focus so that the surrounding flash can disappear from the spot.
11. After G-Focus adjustments are complete, adjust R-Focus as above procedures.
12. The B-CRT adjustments can be omitted because the variance of beam focus is small.
(Only Vm-coil is mounted.)
13. Adjust the Focus-pack VR for fine focusing.
14. Press the  button on the remote control, and the mode changes to the Convergence Adjustment mode.
15. Press the  button on the remote control to return to normal viewing.

2-6 Convergence-Jig

2-6-1 HCN479W

X 1045, Y 588 (X:396=12*2+ 31*12, Y:48 8=40*2+68*6)

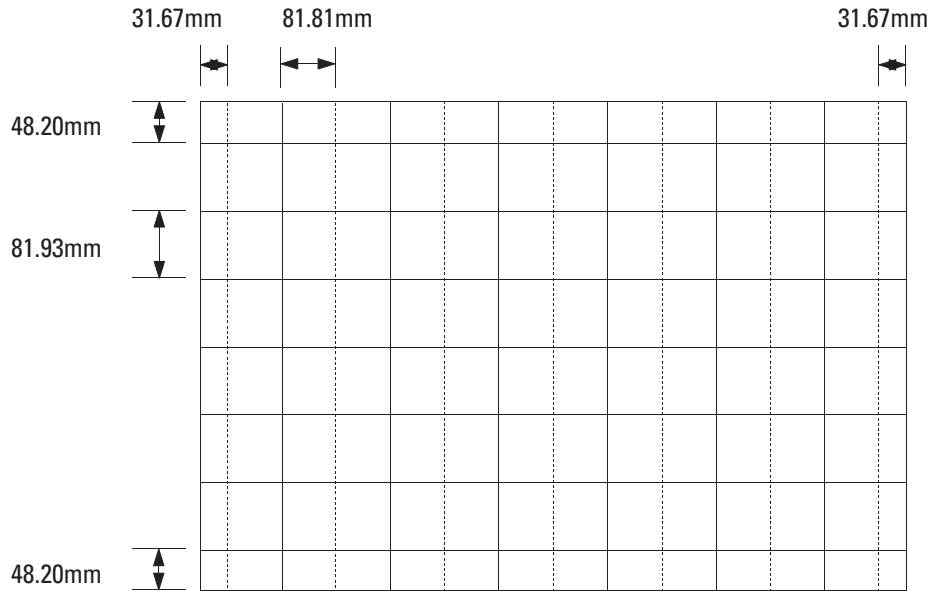

2-6-2 HCN559W/5529W

X 1225, Y 686 (X:396=12*2+ 31*12, Y:48 8=40*2+68*6)

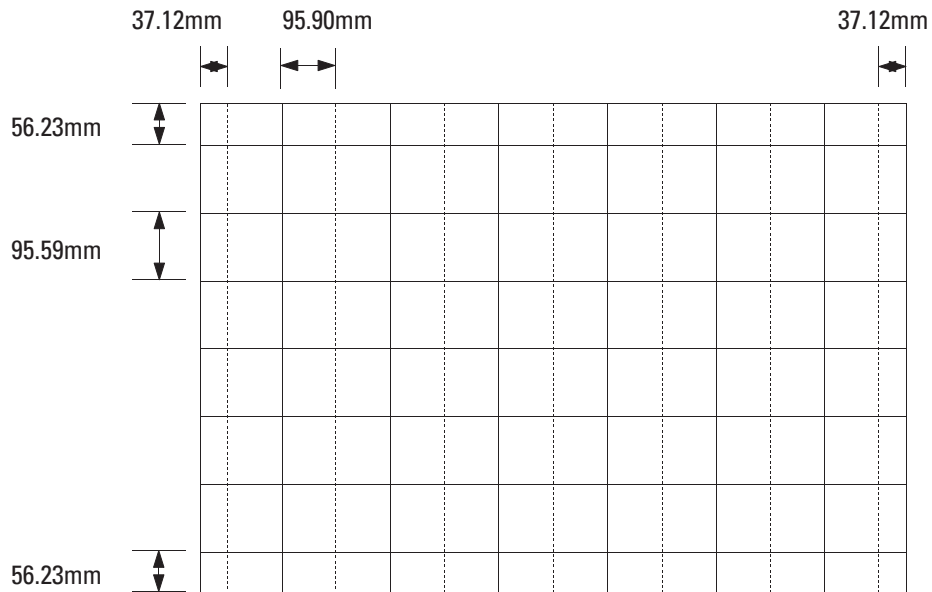

2-6-3 HCN659W

X 1442, Y 838 (X:396 =12*2 +31*12, Y:488=40*2+68*6)

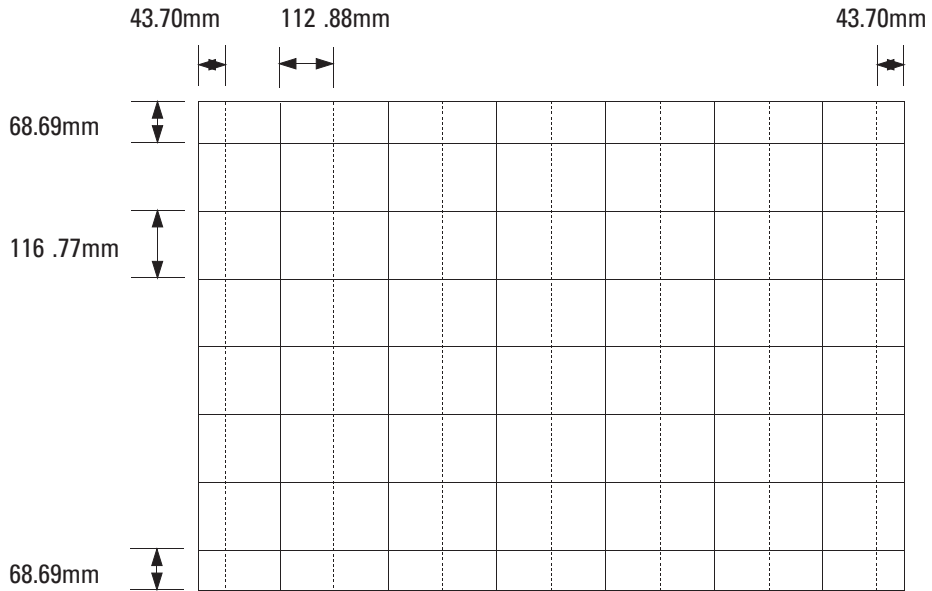

2-6-4 HCN529W



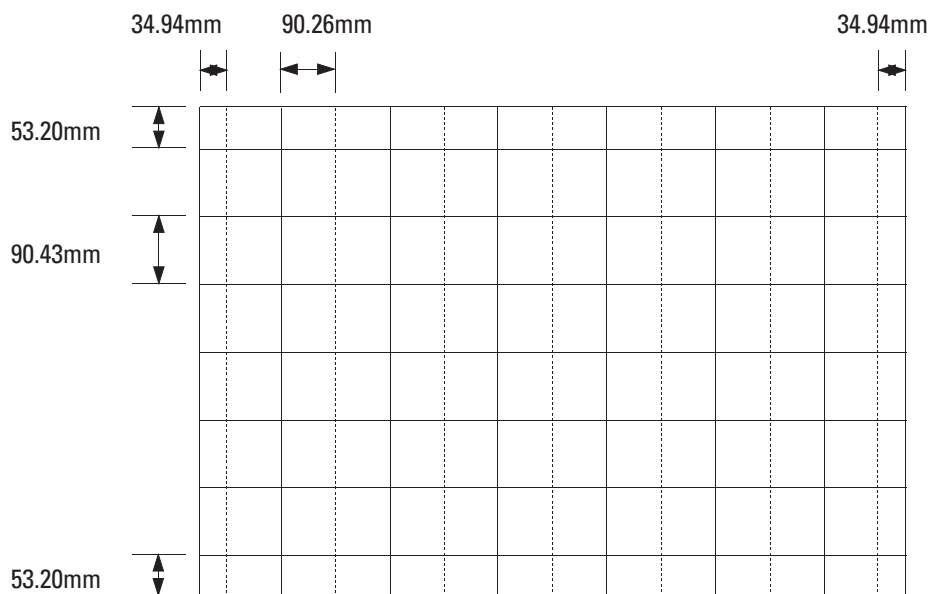



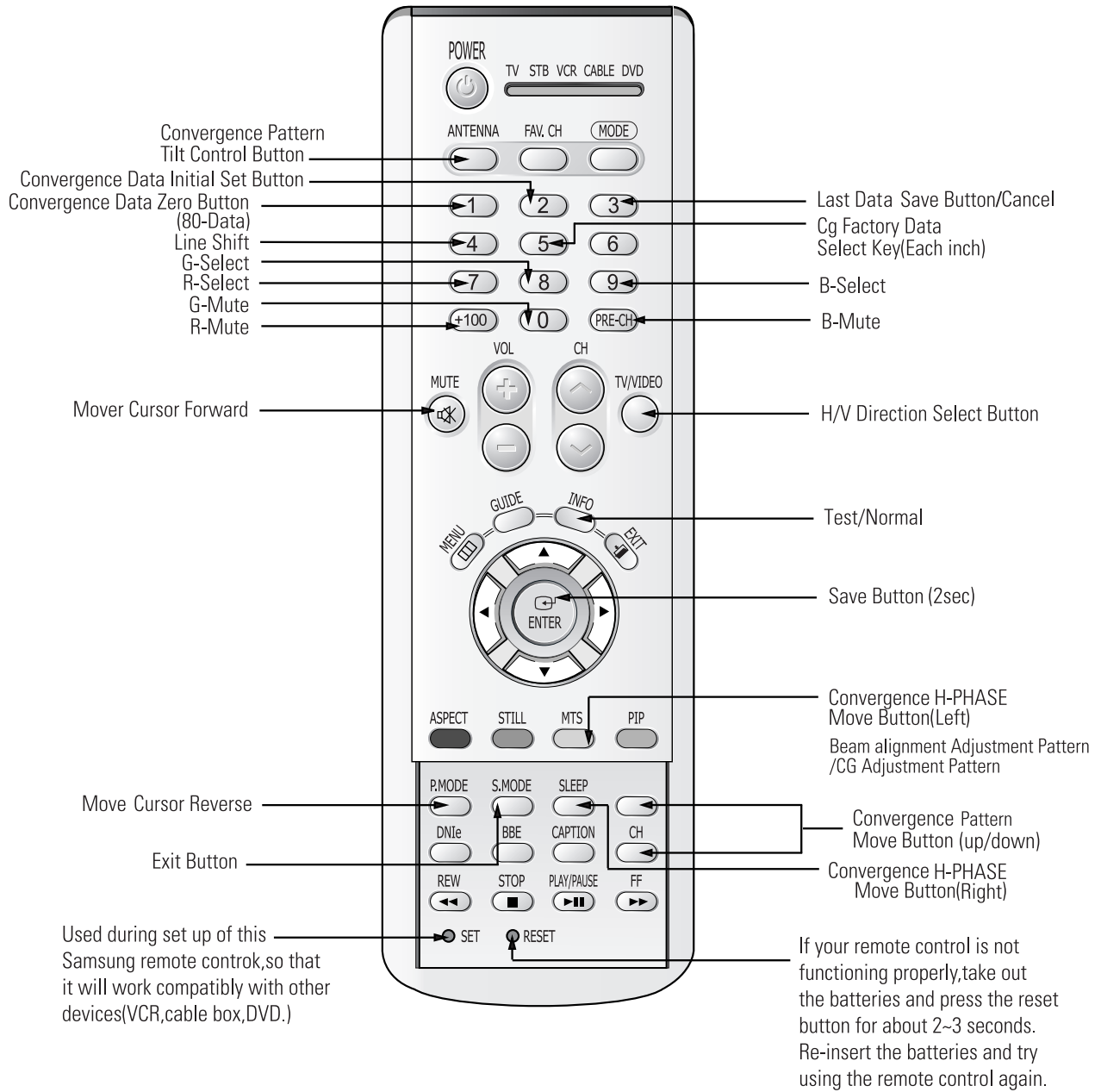





X 1153, Y 649 (X:396=12*2+ 31*12, Y:488=40*2+68*6)





2-7 Remote Control Key Functions in Convergence Mode



2-7-1 KEY Function

1. R-SELECT 
Press to select RED color.
2. G-SELECT 
Press to select GREEN color.
3. B-SELECT 
Press to select BLUE color.
4. R-MUTE 
Press to mute RED color.
5. G-MUTE 
Press to mute GREEN color.
6. B-MUTE 
Press to mute BLUE color.
7. CANCEL KEY 
Press to revert to the previous data during the Convergence Adjustment.
8. TEST/NORMAL 
Press to check TV mode in the Convergence Mode.
9. LINE SHIFT 
Press to move a line up/down or left/right.
10. FACTORY DATA SELECT BUTTON 
Press to call the factory default values.
11. H/V DIRECTION SELECT BUTTON 
Press to switch the cursor direction horizontally or vertically.
12. SAVE BUTTON 
After the Convergence Adjustments are completed, press to save data.
13. EXIT BUTTON 
After the Convergence adjustments are completed, press to exit to TV mode.

14. MOVE CURSOR FORWARD 
 Press to move the cursor right or down.

15. MOVE CURSOR REVERSE 
 Press to move the cursor left or up.

16. CONVERGENCE PICTURE MOVE BUTTON

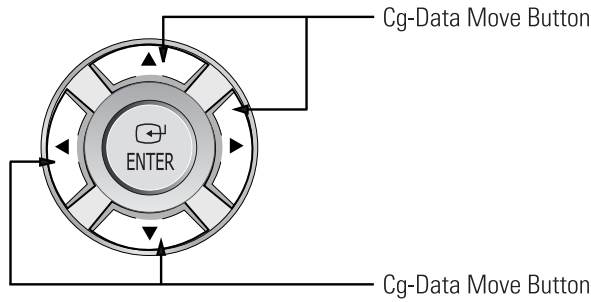

17. CONVERGENCE MOVE BUTTON
 Press to move the convergence left () or right () .

18. CONVERGENCE DATA ZERO BUTTON 
 Press to zero the convergence correction data.

19. INITIAL DATA SET BUTTON 

20. Convergence Pattern Tilt Control Button 
 After pressing the ANTENNA button, use the Channel Up/Down and Volume +/- buttons to create a tilt to the Convergence Pattern.

 **NOTE** Note : Use the following two buttons only when they are indispensable.

21. Beam alignment Adjustment Pattern achieve Button 

2-8 Convergence Adjustment

2-8-1 Convergence Adjustment)

NOTE Special Notes

- ⇒ A sensor is attached on the center of each side of the Convergence Mode pattern (see figure below). The sensors are required for normal Perfect Focus function.
- ⇒ Use a screen jig to do the convergence adjustments correctly (Especially, perform correct convergence adjustments on the center of each side where a sensor is located.)
- ⇒ Do the convergence adjustments correctly. Otherwise, any Perfect Focus error can happen.

1. Warm up the TV for a least 30 minutes.
2. Input an NTSC Signal.(Use an antenna or AV source.)

NOTE Make sure that deflection yoke are properly adjusted so that the center of Green, Red, Blue pattern is aligned on the center of screen jig.

3. Enter the Convergence Mode by Pressing the remote control keys in the following sequence:



NOTE If OSD displayed as shown in figure below, press the **S.MODE** key to exit. Then, redo step 3 to enter the Convergence Mode. After entering the Convergence Mode, Stand by for about five seconds before doing the adjustments.

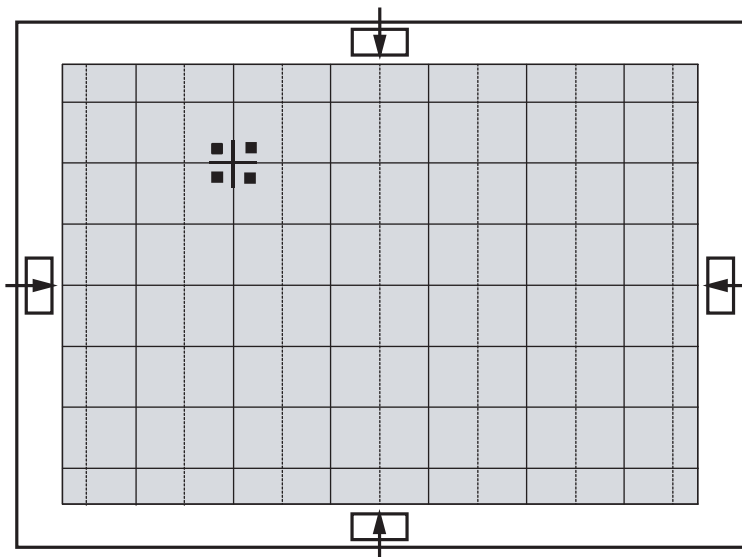

4. To adjust GREEN, first press the **+100** and the **PRE-CH** keys, and then press the **8** key. Press to move the cursor right or down.



5. The **TV/VIDEO** key moves the cursor horizontally or vertically.

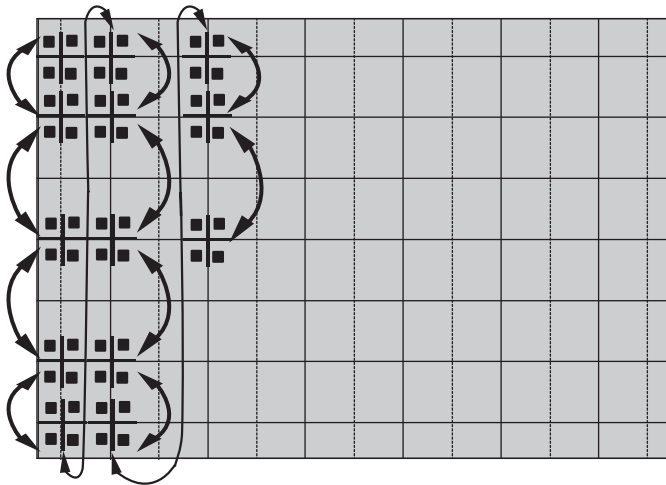

When the **TV/VIDEO** key is pressed once again, the cursor moves horizontally.

6. The **MUTE** key moves the cursor right, and the **P.MODE** key moves the cursor left.

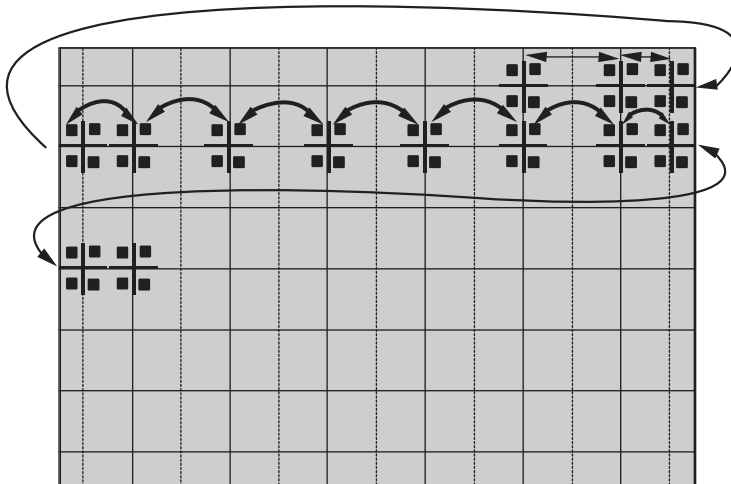

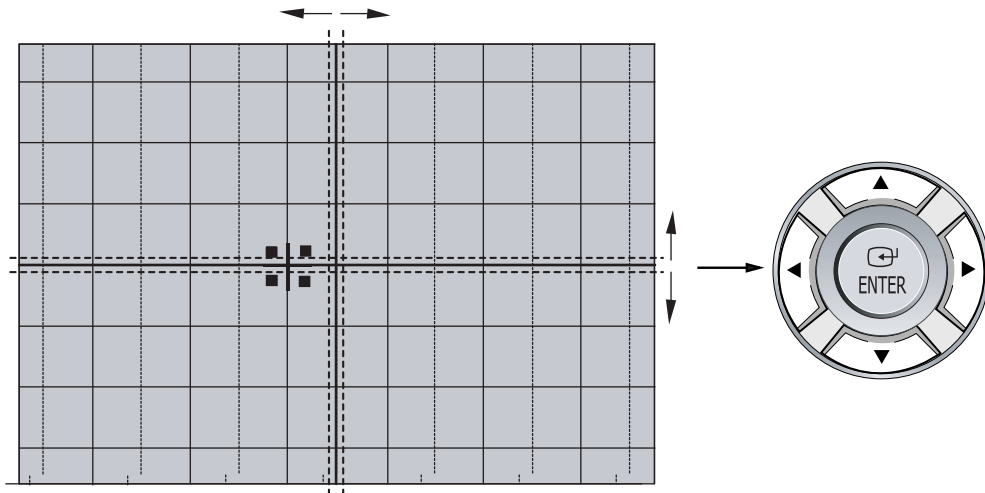

7. Use the **4** key for overall balance.



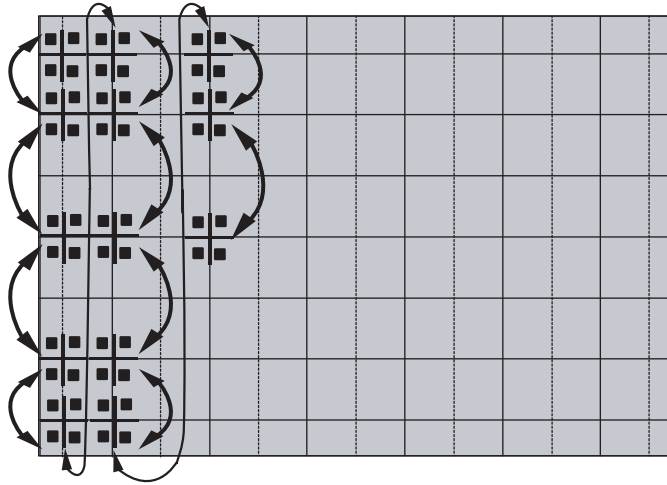

8. After the Line Shift is cancelled by pressing the **4** key, use the Channel and Volume keys (Up/Down) to make big adjustments.
9. After the green convergence adjustments are completed, press the **ENTER** key to save the data.
10. Superimpose the Red and Green colors by pressing the **+100** and the **7** keys.

11. To adjust RED, redo steps 5~7.



When the cursor moves vertically 

12. To superimpose the blue and green colors, press (1) the  key for R-Mute, (2) the  key to cancel the B-Mute, and (3) the  key for B- select

13. To adjust BLUE, redo steps 5~7, 13.

14. If any color is not properly adjusted when displaying the red, blue and green colors, readjust the color.

15. After the color adjustments are completed, press the () key to save the data.



The cursor moves to center, and then automatically moves up and to the left about five seconds later.

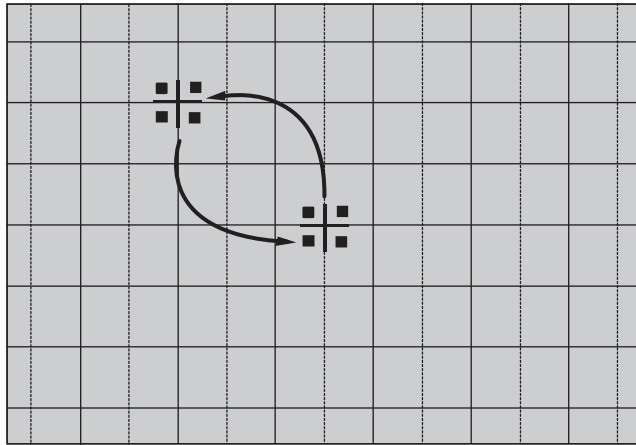

2-8-2 Perfect Focus (Factory Mode)

1. After the adjustment is completely saved, press the perfect Focus key to perform Auto Convergence (Factory Mode). Auto Convergence is performed in the following sequences :

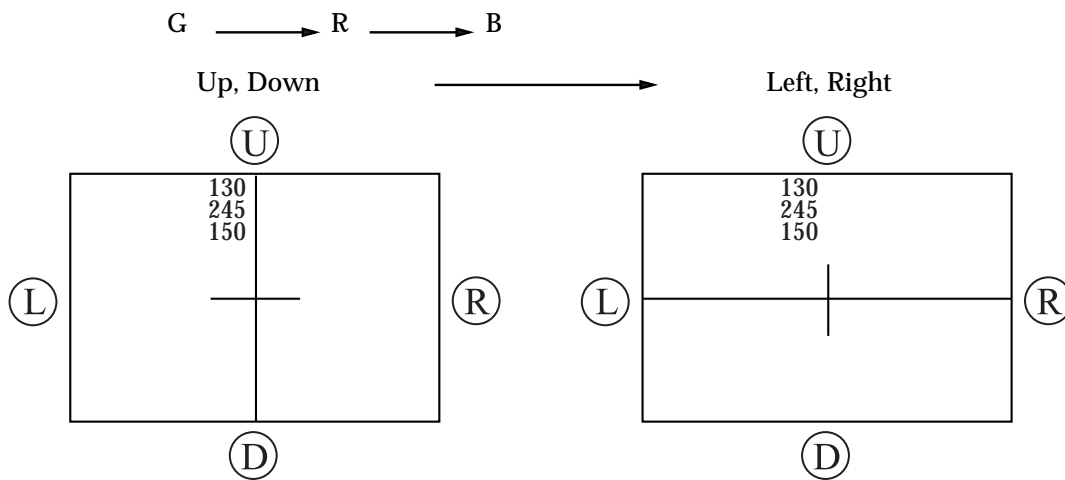

When auto Convergence is complete, the data is automatically saved and the convergence pattern reverts.



Convergence must be adjusted and saved correctly before Perfect Focus can be performed. Otherwise, a “No Sense Data” error message will appear.



- After Factory Auto convergence is complete, make sure that the cursor flickers for about 1 second on the center and then it is saved.
- OSD shows error.
- When any error happens, be sure to re-do Factory Auto Convergence.
- When Convergence Adjustment is not normally done or the convergence center is misaligned with the sensing point, any adjustment error happens. Therefore, be sure to use a screen jig to correctly adjust during troubleshooting.

2. After the Convergence Adjustments are complete, press the  key to exit.
3. DTV Convergence adjustment must be done same as the above Normal Mode Convergence Adjustment (Use a 16 : 9 screen jig for DTV)



When Convergence Adjustment is not normally done or the convergence center is misaligned with the sensing point, any adjustment error happens. Therefore, be sure to use a screen jig to correctly adjust during troubleshooting.

■ Changes when applying Almighty-Cg, Module (How to extract the basic Cg Data)

Inch	Model Name	Data	Screen Display
47"	CN479W	5- 473	□ □ □ □
52"	HCN529W	5- 521	+ + + + +
55"	HCN559W HCN5529W	5- 553	□ □ □ □ □
65"	HCN659W	5- 653	□ □ □ □ □ □

2-9-2 MV-MODULE / CG-MODULE PIN

CG-MODULE PIN SPEC

CN700				
No.	NAME	No.	NAME	NAME
1	5V-CG	17	GND	GND
2	GND	18	GND	GND
3	D/F	19	BV	BV
4	GND	20	BH	BH
5	SCL-M5	21	GV	GV
6	CG-F/B	22	GH	GH
7	GND	23	RV	RV
8	NC	24	RH	RH
9	CG-R	25	GND	GND
10	CG-G	26	H-BLK	H-BLK
11	CG-B	27	V-BLK	V-BLK
12	SDA-M5	28	GND	GND
13	NC	29	NC	NC
14	IR	30	-5V	-5V
15	CG-F/B	31	5V	5V
16	GND	32	GND	GND

MV-MODULE PIN SPEC

CN202				
No.	NAME	No.	NAME	NAME
1	13.5V	33	GND	IR
2	SAM-HS0	34	GND	STB-5V
3	GND	35	MICOM-D6	GND
4	SAM-VS0	36	POWER	GND
5	D/F	37	MICOM-D4	KEY3
6	GND	38	MICOM-D5	V-BLK
7	VM-Y	39	MICOM-D2	KEY1
8	SAM-Pr0	40	MICOM-D3	H-BLK
9	GND	41	MICOM-D0	KEY2
10	SAM-Pb0	42	MICOM-D1	GND
11	VD+	43	GND	GND
12	SAM-Y0	44	MICOM-INT	SCL-MICOM
13	VD-	45	COMB-C	CAPTION-V/Y
14	GND	46	MAIN-C	SDA - MICOM
15	EW	47	COMB-V/Y	1080I-SW
16	CG-R	48	MAIN-Y	PROTECT
				GND